

Session Number:8B  
Session Title: *Contributed Micro Papers: Issues in Income Distribution*  
Paper Number: 18  
Session Organizer: Edward Wolff  
Discussant:

*Paper Prepared for the 28<sup>th</sup> General Conference of  
The International Association for Research in Income and Wealth  
Cork, Ireland, August 22 – 28, 2004*

**TRENDS IN INEQUALITY AND POVERTY IN THE EU FROM 1993 TO 1999  
USING SETS OF DIFFERENT MEASURES**

**JUANA DOMÍNGUEZ-DOMÍNGUEZ  
J. JAVIER NÚÑEZ-VELÁZQUEZ  
LUIS F. RIVERA-GALICIA**

For additional information please contact:

Author Name(s) Juana Dominguez-Dominguez  
J. Javier Núñez-Velázquez  
Luis F. Rivera-Galicia  
Author Address(es) Departamento de Estadística, E.E. y O.E.I.  
Facultad de Ciencias Económicas y Empresariales  
Plaza de la Victoria, s/n, 28802 Alcalá de Henares (Spain)  
Author E-Mail(s) [juana.dominguez@uah.es](mailto:juana.dominguez@uah.es)  
[josej.nunez@uah.es](mailto:josej.nunez@uah.es)  
[luisf.rivera@uah.es](mailto:luisf.rivera@uah.es)  
Author FAX(es) +34 918854201  
Author Telephone(s) +34 918854277  
+34 918854276  
+34 918854280

This paper is posted on the following websites:<http://www.iariw.org>  
<http://www.econ.nyu.edu/iariw>  
<http://www.cso.ie/iariw/iariwhome.html>

# **TRENDS IN INEQUALITY AND POVERTY IN THE EU FROM 1993 TO 1999 USING SETS OF DIFFERENT MEASURES<sup>1</sup>**

**JUANA DOMÍNGUEZ-DOMÍNGUEZ, J. JAVIER NÚÑEZ-VELÁZQUEZ and  
LUIS F. RIVERA-GALICIA**

**Departamento de Estadística, E.E. y O.E.I.**

**Facultad de CC. Económicas y Empresariales, University of Alcalá (Spain)**

## **ABSTRACT**

The purpose of this paper is to analyze the evolution of economic inequality and poverty in the 15 countries of E.U., whose household income data is available through the information contained in the European Community Household Panel (ECPH). This analysis allows static as well as dynamic comparisons, related to the period from 1993 and 1999. Furthermore, the determination of groups of countries according to their characteristics in inequality and poverty will be accomplished.

Different tools have been proposed for the analysis and the measurement of economic inequality and poverty. One of these tools is the Lorenz curve for inequality and the TIP curve for poverty. Their main inconvenience is that they do not always produce complete orderings, because curves corresponding to different income distributions may have crossings. This non-comparability problem can be solved with inequality and poverty index numbers, which allow complete orderings. Some inequality measures take more into account the incomes located in one or the two tails of the income distribution, others the central part, etc. Regarding poverty measures, some of them take into account where the smallest incomes are located inside the whole distribution, others the place of these incomes in poor population, others characterize the poverty gaps, etc. These circumstances allow different orderings to be produced according to these inequality or poverty indexes.

---

<sup>1</sup> The authors thank financial support from Research Projects PBI-03-001, provided by the Junta de Comunidades de Castilla-La Mancha and Fondo Social Europeo (70%), and PI-UAH2004/034, provided by University of Alcalá. ECHP data are used under permission of EUROSTAT contract ECHP/15/00, held with the University of Alcalá.

Synthetic measures of inequality and poverty will be proposed and constructed using a set of indicators. These synthetic measures will contain the information supplied by this set of one-dimensional inequality or poverty indexes, which verify certain postulates. To obtain these synthetic measures, we apply the Principal Component Analysis (PCA) technique to a set of one-dimensional inequality or poverty indicators, so that we can account for most of the variation in the original data. Thus, a new procedure to construct a synthetic indicator in each temporal reference is proposed for inequality and poverty. Properties of these synthetic indicators will also be analyzed.

In order to obtain comparable values throughout time, in addition to cross-sectional sense, joint consideration of single inequality or poverty indicators is proposed, independently of their temporary period of reference. Therefore, applying PCA to this data, a common frame of comparison and a homogeneous weighting structure are obtained, which are stable throughout time.

In order to give validity to this exposition, a study of the structure of the simple indicators variance-covariance matrices in the different considered periods of time is made, using Box's M-test to verify if matrices of all periods are equal. If the hypothesis of equality of covariance matrices is rejected, the use of common space technique (Krzanowski, 1979, 1982) is proposed.

**JEL CLASSIFICATION:** D31, D63, O52

**KEY WORDS:** Economic Inequality, Economic Poverty, European Union

## 1. INTRODUCTION

Economic inequality and poverty have always been two of the most recurrent research fields in economics, because they are related to several important tasks, not only in economics but also social, political and many other ones. In this sense, Sen (1973) pointed out how inequality can be connected to many causes of uneasiness, including social rebellions indeed. Also, implications in other interesting economic concepts should be recognized, such as convergence, welfare and so on. Nevertheless, the last decades have seen an appreciable researchers' interest increase in several aspects related to poverty and economic inequality. Probably, this new increasing interest began since the publication of works like Atkinson (1970, 1987) and Sen (1973, 1976). All of them have been considered as seminal studies focused in basic aspects such as quantitative measuring, economic theoretical background or inequality and poverty comparisons.

In both cases, the need for a multidimensional framework has been sometimes proposed because there might be monetary and non-monetary elements involved in their measurement. However, this option implies many problems related to the lack of available data (Laderchi, 1997). So, the current option consists of selecting some proxy variable for the household economic position, like a summary, which will be our option in this work.

Lorenz curve constitutes perhaps the most general agreement related to methods for measuring inequality. Since its presentation in Lorenz (1905), these curves remain as useful and comprehensive tools for comparing the accumulated percents of perceiving units and perceived resources, giving as a result the extent of inequality in the statistical distribution<sup>2</sup>. For the sake of income distribution comparisons, it is well known that Lorenz curves will only generate valid results if they are completely nested and then the Lorenz curve closer to the uniform one is said to represent less inequality. Nevertheless, this so-called *Lorenz dominance criterion* allows only a quasi-order relationship among the set of income distributions, because intersections between Lorenz curves occur very often. Shorrocks (1983) proposed a generalized curve using the income mean to rescale the Lorenz curve ordinates, defining a *generalized Lorenz dominance criterion* to compare

---

<sup>2</sup> General details can be found in Kendall and Stuart (1977), for example.

income distributions in a similar way. However, intersections may occur, generating also a quasi-order relationship, but the underlying concept under these curves isn't yet inequality exactly, including income-welfare aspects. These elements constitute an active research field, with connections to stochastic dominance concepts<sup>3</sup>.

The natural way to overcome the difficulties associated with partial orders consists of the proposal of inequality measures. These indicators will summarize all income inequality content in a single number, making a total order relationship possible over the income distribution space. Obviously, it seems clear that these indicators must be compatible with Lorenz criterion, which can be characterized by four well-known properties (Foster, 1985). Nevertheless, these restrictions result to be weak because there are a great number of inequality indexes fulfilling them. So, it is difficult to reach agreement with the selection of a better inequality measure, resulting a set of them for use in current practice<sup>4</sup>. There are several research fields related with the study of reasonable restrictions looking for isolating some index among the above-mentioned set. So, some authors are trying to restrict the so-called *Pigou-Dalton Transfers Principle* in an economic-based suitable way<sup>5</sup>. Other research field consist of imposing additional properties to narrow the set of available indicators; among these properties, it must be remarkable the use of the *additive decomposition properties* (Bourguignon, 1979) in order to separate *between-groups inequality* and *intra-groups inequality* in an additive manner, when population is divided into subgroups. Another selection task consists of considering social welfare functions defined on economic theoretical grounds as an underlying support of inequality measures, but this research field presents hard controversies too<sup>6</sup>.

When we have to manage with poverty concepts, difficulties arise just at the beginning, when we define a poor household through the poverty line concept, which permits us the study of *poverty incidence*. Again, this problem is not easy to solve, and there are a great number of proposals<sup>7</sup>. Nevertheless, difficulties arises again if poverty

---

<sup>3</sup> See Bishop, Formby and Sakano (1995), Davies and Hoy (1994) or Muliere and Scarsini (1989), for example.

<sup>4</sup> Núñez (2002), among others.

<sup>5</sup> Further details can be seen in Shorrocks and Foster (1987) or Davies and Hoy (1995).

<sup>6</sup> See Atkinson (1970) and Dagum (1990), for example.

<sup>7</sup> Further details can be found in Hagenaars and van Praag (1985).

comparisons should be accomplished, because use of global curves<sup>8</sup> generates only a quasi-order structure and aggregate poverty indicators are then needed to measure *poverty intensity* (Sen, 1976).

Despite the above discussions, the difficulty in choosing one better inequality or poverty measure remains. The underlying problem arises because different measures may lead to different orderings. Essentially, most of the inequality measures we are talking about hide several weighting schemes defined over the Lorenz curve ordinates, obeying the different ideas under their construction. So, we propose the use of a whole set of admissible inequality measures in order to extract their common information, which will be inequality, in essence. Beyond this idea, our proposal of a synthetic inequality indicator will be capable to study dynamic trends too, after the necessary technical adjustments, which configures its newness.

A similar argumentation can stand if poverty measures are considered. Perhaps, in order to choose a better poverty measure, the most accurate research field consists of imposing a minimum framework with necessary properties, so called axioms (Foster, 1984; Foster and Sen, 1997), which must be fulfilled by this measure, to be considered as a good one. However, there is neither agreement about which measure is the best nor what properties should be considered among a great number of proposed axioms. Thus, the same solution can be proposed in such a context, related to the consideration of simple indicators batteries, in order to construct a synthetic indicator from them.

Nevertheless, studies on trends of inequality and poverty are not new, but all of them use selected simple inequality and poverty measures or partial orders derived of domination relationships schemes such as Lorenz curve, generalized Lorenz curve, TIP curves or stochastic dominance-based. Some examples referred to different countries are Lovell (1998), using Lorenz dominance and several inequality measures; Jenkins (1995), Achdut (1996) and Frick and Grabka (2003), using several inequality measures and the decomposition property of some of them, Bishop, Formby and Smith (1991), using Lorenz

---

<sup>8</sup> Among this proposals, we might quote poverty orderings (Atkinson, 1987; Foster and Shorrocks, 1988a, 1988b) and TIP curves (Jenkins and Lambert, 1997).

dominance, or Jenkins and Lambert (1997) and Del Río and Ruíz-Castillo (2001), using TIP curves in comparisons of poverty levels.

The structure of this paper is as follows. In section 2, data used will be described. In section 3, general methodology will be presented, and some modifications to adequate this methodology to our study will be introduced. In section 4, results obtained will be presented and commented. The concluding section will summarize the main results obtained and will attempt to suggest possible directions for future research.

## **2. DATA DESCRIPTION.**

The computation of inequality and poverty indexes will be accomplished using data from the European Community Household Panel (ECHP). ECHP is a longitudinal survey of households and individuals, centrally designed and coordinated by the Statistical Office of the European Communities (EUROSTAT) and covering all countries of the European Union. An attractive feature of ECHP is its comparability across countries and over time, as the questionnaire is similar and the elaboration process of the survey is carried out by EUROSTAT (Álvarez-García, Prieto-Rodríguez and Salas, 2002).

The economic position of households we have chosen for this paper, as a shake of convenience, is total net household income, which is one of the variables included in ECHP. In order to consider household size, to account for inner scale economies, *per capita* net income has been calculated, instead of any other household equivalence scale<sup>9</sup>. It is well known that levels in measured income inequality and poverty can vary depending on the choice of equivalence scale, although none of them has been proved to be superior. The purpose of this work is not to analyze the influence of equivalence scales on income inequality and poverty, but to see the way in which a set of indicators can be aggregated (for further discussion on equivalence scales, see, for example, Coulter, Cowell and Jenkins, 1992, Buhmann, Rainwater, Schmaus, and Smeeding, 1988, or Casas, Domínguez and Núñez, 2003, in the spanish case, among others).

---

<sup>9</sup> See, for example, Duclos and Mercader-Prats, 1999.

In order to face a comparative study of poverty in the European countries, in a cross-sectional as well as in a longitudinal sense, per capita net household income has been transformed into US dollars, using exchange rates obtained from EUROSTAT. Furthermore, time series have been deflated using European Union Harmonized Consumer Price Index for each country, referred to 1995, to avoid the effect of inflation, when longitudinal comparisons involving poverty lines are going to be performed.

We are not going to provide here a full description of the ECHP dataset in terms of sampling, response rates, weighting procedures, etc., since those can be easily found in specialized literature (EUROSTAT publications and web page, Nicoletti and Peracchi, 2002, Ayala and Sastre, 2002, etc.), but it is necessary to point out that we had to exclude some households from the dataset in our analysis because they presented missing values for total net household income. Table 1 shows the initial number of cases in each country and the number of households that were finally selected. It is interesting to notice the large amount of households from Sweden for which this variable is not available. Despite Layte, Maître, Nolan and Whelan (2000) indicate that they had excluded Luxembourg because it must be frequently treated as an exceptional case, we haven't found empirical evidence to discard this case, or any other. Although Austria, Finland and Sweden were not included in the first waves of the ECHP, we have decided to include them in those waves where their data are available, in order to enrich the comparative results.

In this paper, we have taken into account the information from waves 1 to 7, which correspond to years 1994 to 2000 (last wave available when this work was developed). As it is well known, income data of each wave is always referred to the previous year, thus giving us information about years 1993 to 1999.

**Table 1**

*Total sample sizes and sample size for households with total net income, in brackets.  
ECHP Countries, Waves 1 to 7.*

<b>Country</b>	<b>Code</b>	<b>Wave 1 1993</b>	<b>Wave 2 1994</b>	<b>Wave 3 1995</b>	<b>Wave 4 1996</b>	<b>Wave 5 1997</b>	<b>Wave 6 1998</b>	<b>Wave 7 1999</b>
<b>Denmark</b>	<b>DK</b>	3482 (3478)	3223 (3218)	2955 (2951)	2745 (2740)	2512 (2505)	2387 (2381)	2281 (2273)
<b>Netherlands</b>	<b>NL</b>	5187 (5139)	5110 (5035)	5179 (5097)	5049 (5019)	4963 (4922)	5023 (4981)	5008 (4976)
<b>Belgium</b>	<b>BE</b>	3490 (3454)	3366 (3343)	3210 (3191)	3039 (3013)	2876 (2863)	2712 (2691)	2571 (2555)
<b>France</b>	<b>FR</b>	7344 (7108)	6722 (6679)	6600 (6555)	6176 (6142)	5866 (5849)	5610 (5594)	5345 (5331)
<b>Ireland</b>	<b>IE</b>	4048 (4038)	3584 (3569)	3173 (3164)	2945 (2935)	2729 (2723)	2378 (2372)	1951 (1944)
<b>Italy</b>	<b>IT</b>	7115 (6915)	7128 (7004)	7132 (7026)	6713 (6627)	6571 (6478)	6370 (6273)	6052 (5989)
<b>Greece</b>	<b>GR</b>	5523 (5480)	5220 (5173)	4907 (4851)	4604 (4543)	4211 (4171)	3986 (3952)	3918 (3893)
<b>Spain</b>	<b>ES</b>	7206 (7142)	6522 (6449)	6267 (6133)	5794 (5714)	5485 (5439)	5418 (5301)	5132 (5048)
<b>Portugal</b>	<b>PT</b>	4881 (4787)	4916 (4870)	4849 (4807)	4802 (4167)	4716 (4666)	4683 (4645)	4633 (4606)
<b>Austria</b>	<b>AT</b>	- (-)	3380 (3367)	3292 (3281)	3142 (3130)	2960 (2952)	2815 (2809)	2644 (2637)
<b>Finland</b>	<b>FI</b>	- (-)	- (-)	4139 (4138)	4106 (4103)	3920 (3917)	3822 (3818)	3104 (3101)
<b>Sweden</b>	<b>SE</b>	- (-)	- (-)	- (-)	5891 (5286)	5807 (5208)	5732 (5165)	5734 (5116)
<b>Germany</b>	<b>DE</b>	6207 (6196)	6336 (6329)	6259 (6252)	6163 (6156)	5962 (5955)	5847 (5845)	5693 (5687)
<b>Luxembourg</b>	<b>LU</b>	1011 (1010)	2978 (2976)	2472 (2471)	2654 (2651)	2523 (2521)	2552 (2551)	2373 (2373)
<b>United Kingdom</b>	<b>UK</b>	5126 (5041)	5032 (4999)	5011 (4991)	4965 (4958)	4996 (4975)	4951 (4935)	4890 (4866)

### 3. METHODOLOGY

Through the following paragraphs, we present the different operations that must be performed in order to obtain the synthetic indicator proposed. First of all, the space of incomes is introduced, taking into account that the economic position of the households, as established in data description, is measured by its total net household per capita income<sup>10</sup>.

<sup>10</sup> The subsequent construction would be valid if the household economic position measurement is changed, using any other option, like expenditures, earnings or disposable incomes. Basically, we follow the guidelines exposed in Ruíz-Castillo (1987), where further details can be found.

Let  $X$  be a vector of non-negative incomes, in the usual way. Its dimension is determined by the population size. Thus, the space of incomes can be defined as:

$$D = \bigcup_{N=2}^{\infty} D_N ,$$

where:

$$D_N = \left\{ (x_1, \dots, x_N) : x_i \geq 0, i = 1 \dots N; \sum_{i=1}^N x_i > 0 \right\} .$$

Obviously, the following definitions of the inequality and poverty measures selected, which are real-valued, must be understood to be defined over the above space of incomes.

### 3.1. Selection of a set of inequality indicators.

There are many inequality measures (see for example Foster and Sen, 1997; Nygard and Sandstrom, 1981) and there is no agreement about which one could be the best. However, it's usual to establish a minimal set of properties to limit their scope. Let us consider the four axioms that characterize Lorenz dominance compatibility: *anonymity or symmetry, scale invariance, Dalton's Population Principle and the weak version of the Pigou-Dalton Transfers Principle* (Foster, 1985). We add the *Normalization Axiom* (inequality measures are either zero when all recipients have the same income or one if concentration attains its maximum). In such a case, the selection process could lead to the following simple inequality indicators<sup>11</sup>, whose expressions are given in a descriptive mode, when a general vector of incomes,  $X \in D$ , is considered:

1. Atkinson inequality index<sup>12</sup>, with parameter 0.5:

$$ATKIN0.5 = 1 - \frac{1}{\mu} \cdot \left( \frac{1}{N} \sum_{i=1}^N \sqrt{x_i} \right)^2 ,$$

---

<sup>11</sup> See Pena, Callealta, Casas, Merediz and Núñez (1996) and García, Núñez, Rivera and Zamora (2002), for further details.

<sup>12</sup> The family of Atkinson Index is obtained through the following equation:  $A = 1 - \frac{1}{\mu} \cdot \left( \frac{1}{n} \sum_{i=1}^n x_i^{1-\varepsilon} \right)^{\frac{1}{1-\varepsilon}}$ ,

where  $\varepsilon$  is a parameter of aversion to inequality. The sensitivity of the Atkinson index to different shares of the distribution depends on the value attributed to this parameter. The greater the level of  $\varepsilon$ , the greater the aversion to inequality.

where  $\mu$  is the income arithmetic mean.

2. Atkinson inequality index, with parameter 1:

$$ATKIN1 = 1 - \prod_{i=1}^n \left( \frac{x_i}{\mu} \right)^{\frac{1}{n}}.$$

3. Atkinson inequality index, with parameter 2

$$ATKIN2 = 1 - \frac{\mu_H}{\mu},$$

where  $\mu_H$  is the income harmonic mean.

4. Normalized Squared Coefficient of Variation<sup>13</sup>:

$$CV2.NORM = \frac{CV^2}{1 + CV^2},$$

where  $CV$  is the distribution's coefficient of variation.

5. Gini index:

$$GINI = \frac{1}{2n^2\mu} \sum_{i=1}^n \sum_{j=1}^n |x_i - x_j|.$$

6. Pietra or Schutz index:

$$PIETRA = \frac{1}{2n\mu} \cdot \sum_{i=1}^n |x_i - \mu|.$$

7. Normalized Theil index, with parameter 1.

$$TH1.NORM = 1 - \exp(-THEIL1),$$

where  $THEIL1 = \frac{1}{n\mu} \sum_{i=1}^n x_i \cdot \log\left(\frac{x_i}{\mu}\right)$ .

### 3.2. Selection of a set of poverty indicators.

One of the basic problems found when dealing with economic poverty analysis is the identification of poor elements (individuals or households, as in this case) inside the population. This problem can be solved by considering of a poverty threshold (also called poverty line), which can be absolute, relative or subjective. Dagum (1989) argues that poverty line in a poor and less-developed country should be determined from basic needs, whereas for developed countries, relative poverty lines should be used.

---

<sup>13</sup> We prefer the use of normalizing functions instead of another option, which use the maximum value to divide. This last practice might produce Dalton Population Principle failure.

The relative poverty threshold is related to any indicator of the quality of living of society, what Thurow (1969) calls the *adequate living standard* as it is perceived by the majority of society. In this work, we use a time-fixed relative poverty line, defined by the 50% of the mean per capita total net household income for each case considered (the different countries or the EU as a whole), in 1996<sup>14</sup>, and extended to the rest of the years using the corresponding Harmonised Consumer Price Index. In doing so, we intend to avoid the excessively relative impact of choosing different poverty lines defined at each year of the period, allowing us longitudinal comparisons with the same poverty level in each country.

As in the case of inequality indicators selection, there are many poverty measures (see for example Foster, 1984, or Foster and Sen, 1997) and there is no agreement about which one could perform the best. However, it is usual to establish a minimal set of properties to limit their validity. In such a case, the selection process could lead to the following simple poverty indicators<sup>15</sup>, taking into account that  $z$  is the poverty line considered,  $n$  is the number of households in each sample unit and  $q$  identifies the number of poor households (those in which per capita income is under the poverty line):

1. Measure of Sen:

$$SEN(x, z) = \frac{2}{(q+1)nz} \sum_{i=1}^q (z - x_i) (q+1-i).$$

2. Measure of Thon:

$$THON(x, z) = \frac{2}{(n+1)nz} \sum_{i=1}^q (z - x_i) (n+1-i).$$

3. Measure of Foster, Greer and Thorbecke of order 2:

$$FGT2(x, z) = \frac{1}{nz^2} \sum_{i=1}^q (z - x_i)^2 .$$

4. Measure of Foster, Greer and Thorbecke of order 3:

$$FGT3(x, z) = \frac{1}{nz^3} \sum_{i=1}^q (z - x_i)^3 .$$

---

<sup>14</sup> We have chosen 1996, because it is the first year when data are available for all EU countries.

<sup>15</sup> The selected indicators verify the axioms usually imposed in literature. See Domínguez (2003), for further details.

5. Exponential Measure<sup>16</sup>:

$$E(x, z) = \frac{1}{n} \sum_{i=1}^q \left( 1 - \frac{x_i}{z} \right) \exp \left( - \frac{x_i}{z} \right).$$

6. Measure of Chackravarty of order 0.75:

$$CHACK0.75(x, z) = \frac{1}{n} \sum_{i=1}^q \left[ 1 - \left( \frac{x_i}{z} \right)^{0.75} \right].$$

The headcount ratio ( $H=q/n$ ) has been used to analyse the evolution of poverty incidence in the European Countries throughout time. When poverty intensity is studied, we have used the simple indicators previously presented.

### 3.3. Construction of the cross-section synthetic indicators

When dealing with inequality and poverty in the context presented in sections 3.1 and 3.2, we would need the selection of a unique indicator to proceed with the study. However, as long as no argument can be found to choose one of them, our option will be the use of the whole set as a battery of indicators. This approximation isn't new, because Sen (1973) proposed the same idea to compare income vectors using his *intersection relationship*, giving as a result a quasi-order structure defined over the income set ( $D$ ), similar to that produced by Lorenz domination.

Let us begin with the presentation of the data structure where methodology is going to be applied. Consider a set of  $p$  simple indicators<sup>17</sup> ( $I_1, I_2, \dots, I_p$ ), which can be seen as a  $p$ -dimensional variable defined over the income space, whose values have been taken from each case of study (European countries in this paper), and let  $T = \{t_0, t_1, \dots, t_k\}$  be the set of different periods of time considered, when this set of simple indicators is measured. For each  $t \in T$ , we compute the  $p$  simple indicators over the income distribution of each territorial unit considered, thus having a  $(n(t) \times p)$ -dimensional matrix  $I(t)$ , where  $n(t)$  is the number of territorial units at moment  $t$ .

---

<sup>16</sup> This measure is proposed in Domínguez (2003), for example.

<sup>17</sup> Methodology is valid for inequality and poverty indicators simultaneously or, in general, for indicators measuring the same concept.

The formal construction of such a cross-section indicator follows the guidelines exposed in García, Núñez, Rivera and Zamora (2002). Let  $(Y_1(t), Y_2(t), \dots, Y_p(t))$  be the  $p$ -dimensional variable defined using the former variables under standardization along the corresponding cases in  $t \in T$ . Thus, the data matrix will be  $Y(t)$ , whose elements are defined by:

$$Y_{ij}(t) = Y_j(x_i(t)) = \frac{I_j(x_i(t)) - \mu_j(t)}{s_j(t)}, \quad i = 1, 2, \dots, n(t); \quad j = 1, 2, \dots, p; \quad t \in T \quad (1)$$

where  $x_i(t) \in D$  denotes the vector of incomes of the  $i$ th case, measured at moment  $t$  in time,  $\mu_j(t)$  is the mean of the indicator  $I_j$  calculated over all the cases in  $t$  and  $s_j(t)$  its corresponding standard deviation. In such circumstances, let  $R(t)$  be the associated variance-covariance matrix from  $Y(t)$ <sup>18</sup> and let  $u_1(t), u_2(t), \dots, u_p(t)$  be the eigenvectors extracted from  $R(t)$ , associated to its eigenvalues ordered from the largest to the lowest one.

The first principal component can be expressed as follows:

$$Z_1(t) = Z_1(x(t)) = u_1(t) \cdot (Y_1(x(t)), \dots, Y_p(x(t)))' = \sum_{j=1}^p u_{1j}(t) \cdot Y_j(x(t)) \quad (2)$$

with  $x(t) \in D, \quad t \in T$ .

After elementary algebraic manipulations, we have:

$$Z_1(x(t)) + K(t) = \sum_{j=1}^p \frac{u_{1j}(t)}{s_j(t)} \cdot I_j(x(t)),$$

---

<sup>18</sup> As the variables have been standardized, this variance-covariance matrix is equivalent to the correlation matrix of the original variables.

where  $K(t)$  is a value depending on  $u_1(t)$ ,  $\mu(t)$  and  $s(t)$ , but not on  $x(t)$ , except through the vectors expressed. Obviously,  $\mu(t)$  and  $s(t)$  are vectors compounded by the indicators means and standard deviations, respectively.

Finally, the proposed cross-sectional synthetic indicator can be expressed in the following way:

$$Z(x(t)) = \frac{Z_1(x(t)) + K(t)}{\sum_{h=1}^p (u_{1h}(t)/s_h(t))} = \sum_{j=1}^p a_j^*(t) \cdot I_j(x(t)), \quad x(t) \in D, \quad t \in T, \quad (3)$$

with:

$$a_j^*(t) = \frac{u_{1j}(t)/s_j(t)}{\sum_{h=1}^p (u_{1h}(t)/s_h(t))}, \quad j = 1, 2, \dots, p,$$

and we have the synthetic longitudinal indicator as a convex linear combination of the initial simple indicators in the selected battery<sup>19</sup>.

As it can be easily proved, this indicator is compatible with Lorenz domination relationship in the inequality case, verifies minimum set of axioms in the poverty case, and it is a normalized index in both. Furthermore,  $Z(t)$  constitutes an inequality or poverty indicator because it has been constructed using a battery of inequality or poverty indicators, respectively, and this will be the primary content of the first principal component.

### 3.4. A dynamic synthetic indicator.

The synthetic indicator proposed in (3) will only generate different functions on each point in time, because the first eigenvector of  $R(t)$  could change depending on  $t$ . To avoid this problem, we have to remind that data come from samples of households and, thus, correlation matrices are only estimations of the population ones. If we could admit

---

<sup>19</sup> By construction, the elements of the eigenvector  $u_1(t)$  must be non-negative because it was derived from the matrix  $R(t)$ .

that these matrices are all the same, then equality among all the first eigenvectors involved will be considered. In such a case, we might use a pooled estimate of the common variance-covariance matrix in order to obtain a unique eigenvector, which will be independent of time, providing an indicator that will be valid for all periods in  $T$ .

So, as a first option, we propose the use of a test to contrast the hypothesis of a stable variance-covariance structure (correlation in our case). The selected test will be an adaptation of the Box  $\mathbf{M}$ , whose basic details can be found in Rencher (1995), for example<sup>20</sup>.

If the same variance-covariance structure is accepted, then joint consideration of simple indicators is proposed, independently of their temporary period of reference, obtaining the pooled correlation matrix,  $R$ . So, we might use only the first eigenvector,  $u_1$ , valid over the whole time period, and the proposed *global principal component synthetic indicator* can be written as:

$$Z_{GPC}(x(t)) = \sum_{j=1}^p a_j^* \cdot I_j(x(t)) = \sum_{j=1}^p \left( \frac{u_{1j}/s_j}{\sum_{i=1}^p (u_{1i}/s_i)} \right) \cdot I_j(x(t)), \quad t \in T. \quad (4)$$

As it may be observed, the convex linear combination coefficients are now constant across time. So, the incidence of each country income vector operates only through its value measured by the simple indicators, thus allowing their dynamic analysis, because the basic framework is the same, providing a stable weighting scheme over the initial set of indicators. Also, an analysis of the differential facts involved in the individual measuring characteristics could be possible, taking into account the second principal component, which is not going to be done in the present paper.

On the other hand, let us suppose now that null hypothesis of stable correlation structure has been rejected and, therefore, at least one variance-covariance matrix is different. In such a case, it may still be possible to find out another way of solving the

---

<sup>20</sup> Further analytical details related to this process can be found in Domínguez, Núñez and Rivera (2004).

problem of comparison, using an adaptation of an algebraic method to locate the closest vector to the common space generated by principal components, proposed in Krzanowski (1979, 1982), named the *Common Space Analysis* procedure<sup>21</sup>.

Let us expose the aforementioned adaptation of Krzanowski's method. If the first eigenvectors associated to  $R(t)$ ,  $t \in T$ , were close to each other, it would be possible to find out a vector located in a neighborhood near all of them. Using only the first principal components, Theorem 3 included in Krzanowski (1979, pg. 705) permits to assure that the vector we are looking for is the first eigenvector ( $v$ ) of the matrix:

$$H = \sum_{t \in T} u_1'(t) \cdot u_1(t),$$

which maximizes

$$B = \sum_{t \in T} \cos^2 \delta_t,$$

where  $\delta_t$  is the angle between  $u_1(t)$  and  $v$ . This solution is valid only if the first eigenvectors associated to  $R(t)$ ,  $t \in T$  are close, in such a manner that the angles between  $v$  and each of them should be small enough. At this point, it seems reasonable to expect such behavior when we are dealing with indicators that try to measure the same concept. Finally, the alternative synthetic inequality indicator would be the *common space-based synthetic indicator*:

$$Z_{CS}(x(t)) = \sum_{j=1}^p b_j^* \cdot I_j(x(t)) = \sum_{j=1}^p \left( \frac{v_j / s_j}{\sum_{h=1}^p (v_h / s_h)} \right) \cdot I_j(x(t)), \quad t \in T. \quad (5)$$

It comes now evident how if the first proposed synthetic indicator is adequate, the second must be very close to it. Nevertheless, in contexts like inequality or poverty, where

---

<sup>21</sup> An equivalent technique in a more descriptive framework, can be found in Keramidis, Devlin and Gnanadesikan (1987).

high correlations among the indicators should be expected, this second approximation provides an interesting alternative, when the first one fails, in cases where sample oscillations are important.

## 4. EMPIRICAL RESULTS

### 4.1. Inequality trend comparison among European countries.

The corresponding weighting schemes to compute the inequality synthetic indexes based on ACP for each cross-sectional wave are presented in Table 2, obtained from the aforementioned equation 3. We can appreciate that this weighting scheme is quite stable. Thus, we could think that it might be possible to consider that correlation structures are the same all over the period analyzed.

**Table 2**

*Weighting schemes for the computation of the cross-sectional synthetic inequality indexes based on the first Principal Component.*

<b>Inequality Index</b>	<b>Wave 1 1993</b>	<b>Wave 2 1994</b>	<b>Wave 3 1995</b>	<b>Wave 4 1996</b>	<b>Wave 5 1997</b>	<b>Wave 6 1998</b>	<b>Wave 7 1999</b>
<b>ATKIN05</b>	0.295049	0.302812	0.293039	0.292198	0.301918	0.304878	0.312373
<b>ATKIN1</b>	0.146897	0.152037	0.148865	0.149964	0.161265	0.164701	0.169138
<b>ATKIN2</b>	0.023827	0.025343	0.031943	0.022854	0.027188	0.016563	0.024265
<b>CV2NORM</b>	0.038475	0.040558	0.063180	0.068598	0.042177	0.049164	0.032934
<b>GINI</b>	0.114999	0.101305	0.094889	0.099279	0.099808	0.097197	0.095188
<b>PIETRA</b>	0.221298	0.215520	0.208350	0.210289	0.218867	0.217325	0.227021
<b>TH1NORM</b>	0.159455	0.162426	0.159733	0.156817	0.148777	0.150172	0.139080

In order to prove the validity of our intuition, we shall first test the equality of the correlation matrices obtained from data matrix in each wave. Applying M-Box Test on typified data, we can not reject null hypothesis about correlation matrices equality (see Tables 3a and 3b). This fact leads us to take both alternatives presented in methodology section: On the one hand, we compute the Global First Principal Component synthetic indicator on the whole dataset, with no temporal consideration through the pooled correlation matrix; on the other hand, we compute the Common Space-based synthetic indicator.

**Table 3a***Box's M Test on equality of correlation matrices. Inequality indicators.*

Wave	Rank	Log of determinant
<b>1993 correlation matrix</b>	6	-45.750
<b>1994 correlation matrix</b>	6	-47.827
<b>1995 correlation matrix</b>	6	-47.768
<b>1996 correlation matrix</b>	6	-49.342
<b>1997 correlation matrix</b>	6	-48.641
<b>1998 correlation matrix</b>	6	-48.238
<b>1999 correlation matrix</b>	6	-48.122
<b>Pooled correlation matrix</b>	6	-46.754

**Table 3b***Results of M-Box Test.*

Box's M		126.017
F	Aprox.	0.818
	df1	126.000
	df2	12975.749
	Sig.	0.932

Table 4 shows the weights obtained in order to calculate synthetic indicators based on Global Principal Component (from equation 4) and Common Space Analysis (from equation 5), respectively. As it can be easily seen, the corresponding weighting schemes are almost identical. Further, as we could expect, both methods to construct synthetic indicators lead to similar results, when equality of correlation matrices hypothesis is not rejected.

**Table 4***Weighting schemes for the computation of the longitudinal inequality indexes based on the Global First Principal Component and the Common Space Analysis Technique.*

Inequality Index	Global Principal Component Indicator	Common Space Indicator
<b>ATKIN05</b>	0.298972	0.299716
<b>ATKIN1</b>	0.153625	0.154148
<b>ATKIN2</b>	0.025261	0.024624
<b>CV2NORM</b>	0.046800	0.046434
<b>GINI</b>	0.102478	0.101955
<b>PIETRA</b>	0.218497	0.218910
<b>THINORM</b>	0.154366	0.154214

Furthermore, Pearson and Spearman correlation coefficients between these longitudinal synthetic inequality indicators values, and the orderings they produce, respectively, are presented in Tables 5 and 6. Obtained results show high correlations in both cases, as we could expect. In Tables 7 and 8, Pearson and Spearman correlation coefficients between cross-sectional and longitudinal synthetic indicators are shown.

**Table 5**

*Pearson correlation coefficients between Global Principal Component indicator and Common Space Indicator. Inequality.*

		<b>Global Principal Component Indicator</b>	<b>Common Space Indicator</b>
<b>Global Principal Component Indicator</b>	<b>Coefficient</b>	1.000	1.000
	<b>Significance</b>		0.000
	<b>N</b>	106	106
<b>Common Space Indicator</b>	<b>Coefficient</b>	1.000	1.000
	<b>Significance</b>	0.000	
	<b>N</b>	106	106

**Table 6**

*Spearman correlation coefficients between Global Principal Component indicator and Common Space Indicator. Inequality.*

		<b>Global Principal Component Indicator</b>	<b>Common Space Indicator</b>
<b>Global Principal Component Indicator</b>	<b>Coefficient</b>	1.000	1.000
	<b>Significance</b>		0.000
	<b>N</b>	106	106
<b>Common Space Indicator</b>	<b>Coefficient</b>	1.000	1.000
	<b>Significance</b>	0.000	
	<b>N</b>	106	106

**Table 7**

*Pearson correlation coefficients between Global Principal Component indicator and Common Space Indicator and each year's Principal Component indicator. Inequality.*

		<b>Global Principal Component Indicator</b>	<b>Common Space Indicator</b>
<b>1993 Principal Component Indicator</b>	<b>Coefficient</b>	1.000	1.000
	<b>Significance</b>	0.000	0.000
	<b>N</b>	13	13
<b>1994 Principal Component Indicator</b>	<b>Coefficient</b>	1.000	1.000
	<b>Significance</b>	0.000	0.000
	<b>N</b>	14	14
<b>1995 Principal Component Indicator</b>	<b>Coefficient</b>	1.000	1.000
	<b>Significance</b>	0.000	0.000
	<b>N</b>	15	15
<b>1996 Principal Component Indicator</b>	<b>Coefficient</b>	1.000	1.000
	<b>Significance</b>	0.000	0.000
	<b>N</b>	16	16
<b>1997 Principal Component Indicator</b>	<b>Coefficient</b>	1.000	1.000
	<b>Significance</b>	0.000	0.000
	<b>N</b>	16	16
<b>1998 Principal Component Indicator</b>	<b>Coefficient</b>	0.999	0.999
	<b>Significance</b>	0.000	0.000
	<b>N</b>	16	16
<b>1999 Principal Component Indicator</b>	<b>Coefficient</b>	0.999	0.999
	<b>Significance</b>	0.000	0.000
	<b>N</b>	16	16

**Table 8**

*Spearman correlation coefficients between Global Principal Component indicator and Common Space Indicator and each year's Principal Component indicator. Inequality.*

		<b>Global Principal Component Indicator</b>	<b>Common Space Indicator</b>
<b>1993 Principal Component Indicator</b>	<b>Coefficient</b>	0.995	0.995
	<b>Significance</b>	0.000	0.000
	<b>N</b>	13	13
<b>1994 Principal Component Indicator</b>	<b>Coefficient</b>	1.000	1.000
	<b>Significance</b>	0.000	0.000
	<b>N</b>	14	14
<b>1995 Principal Component Indicator</b>	<b>Coefficient</b>	1.000	1.000
	<b>Significance</b>	0.000	0.000
	<b>N</b>	15	15
<b>1996 Principal Component Indicator</b>	<b>Coefficient</b>	1.000	1.000
	<b>Significance</b>	0.000	0.000
	<b>N</b>	16	16
<b>1997 Principal Component Indicator</b>	<b>Coefficient</b>	1.000	1.000
	<b>Significance</b>	0.000	0.000
	<b>N</b>	16	16
<b>1998 Principal Component Indicator</b>	<b>Coefficient</b>	0.994	0.994
	<b>Significance</b>	0.000	0.000
	<b>N</b>	16	16
<b>1999 Principal Component Indicator</b>	<b>Coefficient</b>	0.997	0.997
	<b>Significance</b>	0.000	0.000
	<b>N</b>	16	16

Obtained results prove that longitudinal synthetic indicators constitute a good representation of all cross-sectional synthetic ones, as a whole.

Álvarez-García, Prieto-Rodríguez and Salas (2002) present a general overview of the results on income inequality in European Union countries, during the convergence process to Monetary Union (from 1993 to 1996, they use data of the four first waves of the ECHP). These authors classify the thirteen countries which are present in at least three out of the four ECHP waves considered (excluding Finland and Sweden, since they were included in ECHP from 1996 and 1997 waves, respectively). In their work, a classification of countries into five different groups according to the income inequality is proposed, which is the following: first of all, Denmark is the country where the lowest inequality rate was found during the first four waves. The second group was composed of The Netherlands, Germany, Austria and Luxembourg. United Kingdom, Ireland, Belgium, France, Italy and Spain constituted the third group, meanwhile Greece and Portugal were the fourth and fifth groups, remaining as the most inequal countries.

We have extended this analysis to the last three available waves. Figure 1 shows how our Common Space inequality indicator has the same behavior for Denmark from wave 4 on, and such a behavior is continued until last wave. It can be easily seen that Finland and Sweden show the same pattern that Denmark in this period. Furthermore, we find out that countries with larger values for the synthetic inequality indicator are Portugal, Ireland, Greece and Spain. In the middle, we find the rest of countries, i.e., France, Germany, The Netherlands, Austria, Luxembourg, Italy, United Kingdom and Belgium. These last two countries suffer a serious increase in their synthetic inequality indicator values from fourth wave on. The other six cases show just a slight increase in their inequality levels.

**Figure 1**  
*Common Space Inequality Indicator values for each Country in the ECHP.*

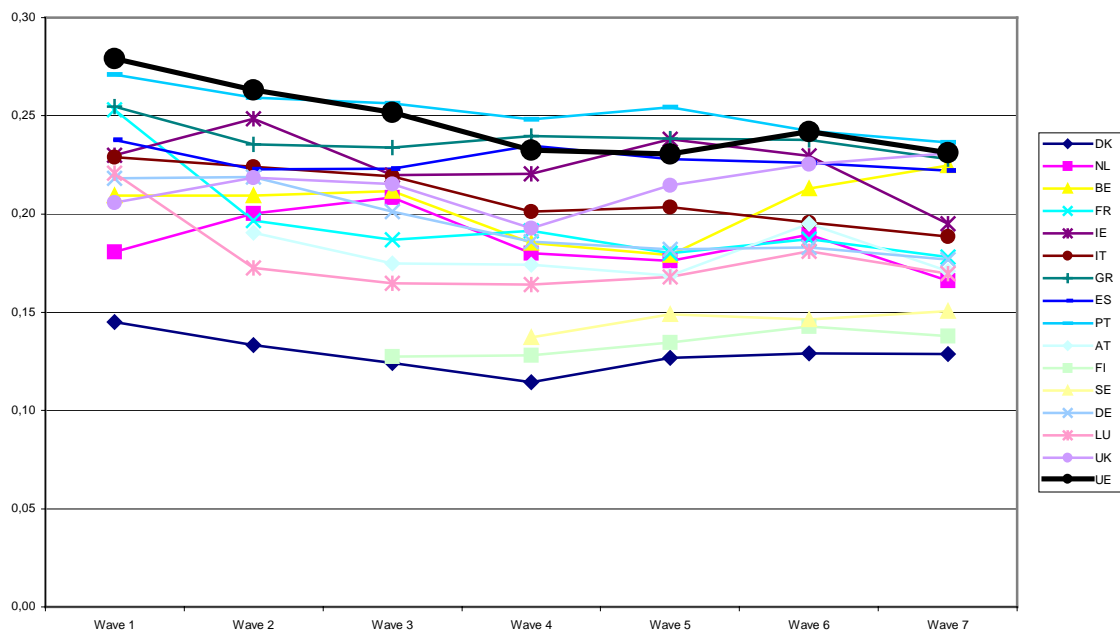

According to temporal evolution of the common space-based inequality indicator, a classification method was used to analyse the group structure in data<sup>22</sup> from wave 4 to wave 7 (omission of the three first waves is necessary because Austria, Finland and Sweden didn't appear, thus not being comparable). The resulting dendrogram is shown in Figure 2.

<sup>22</sup> The centroid agglomeration method of hierarchical clustering has been used over the squared euclidean distance dissimilarity matrix.

**Figure 2**

*Dendrogram of the countries' common space based inequality index referred to waves 4, 5, 6 and 7. Centroid agglomeration method and squared euclidean distance have been used.*

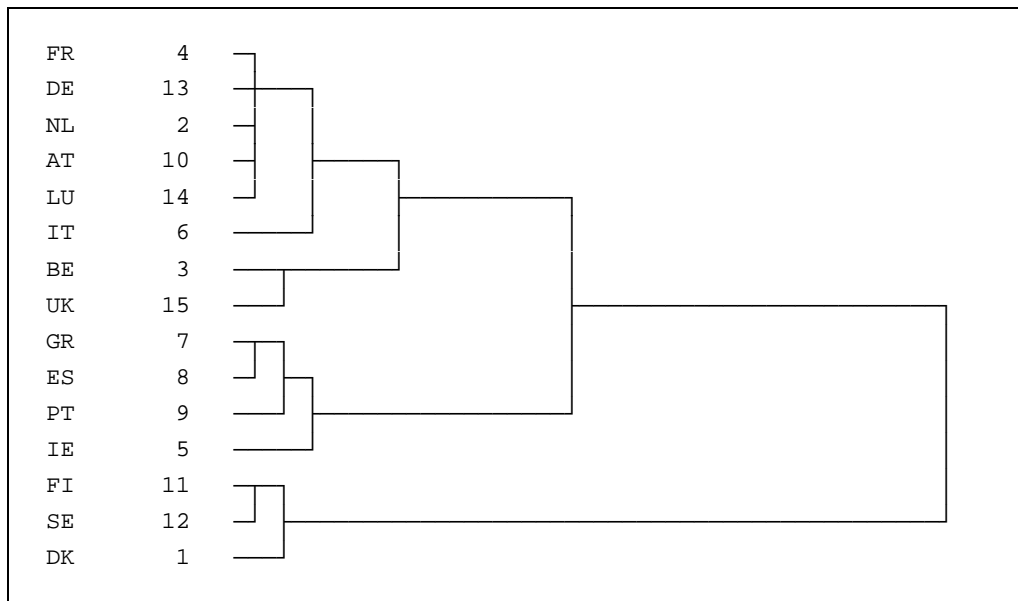

As a fact from Figure 2, we can find out the following four groups:

- The first group is formed by Finland, Sweden and Denmark. These countries present the lowest inequality rates in the EU.
- The second group comprises France, Germany, The Netherlands, Austria, Luxembourg and Italy, which are countries whose inequality is stable and located in the middle of the set of countries.
- The third group is formed by Belgium and United Kingdom, which are countries that show an increase of inequality at the end of the period, that is, between waves 5 and 7 (years 1997 to 1999).
- Finally, the fourth group, composed by Greece, Spain, Portugal and Ireland, presents the greatest inequality indicator levels, thus their income distributions are the most unequal across the EU.

These results are similar to those observed in Figure 1. In Figure 3, the geographical situation of these groups is represented.

**Figure 3**

*Groups of countries derived from the classification according to their inequality level.*

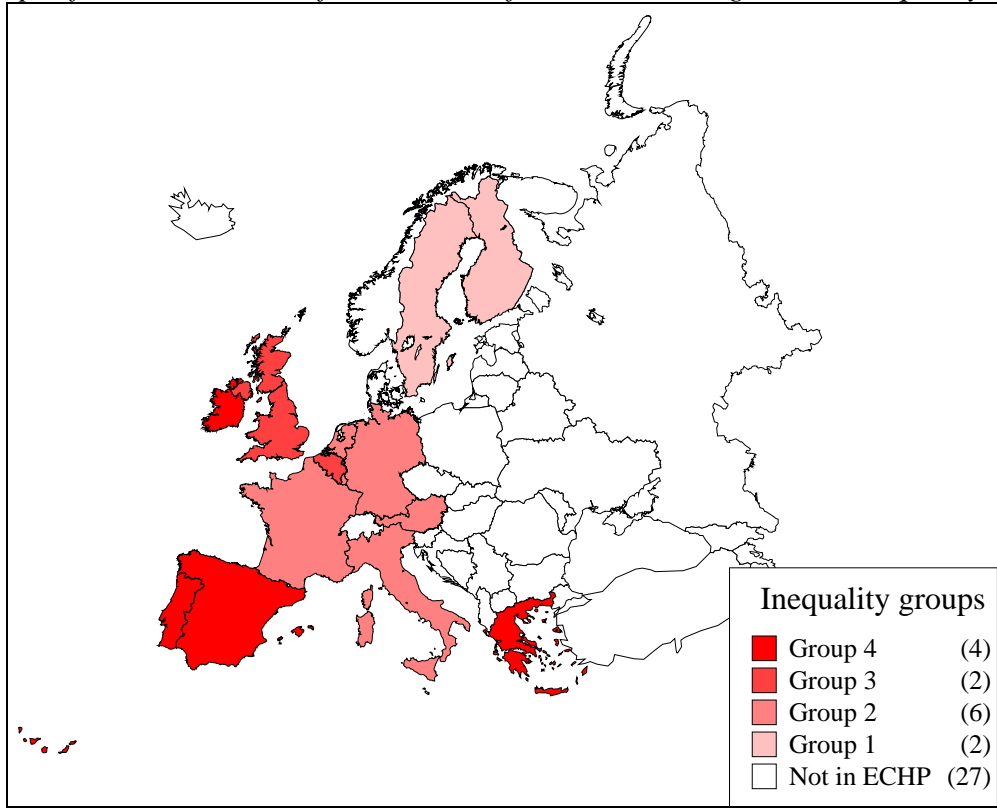

#### **4.2. The incidence of poverty in European countries.**

As we have exposed previously, a relative poverty line was fixed during the whole period in each country, to decide what households should be considered as poor in each country. The poverty threshold was the 50% of the mean of total net household per capita income in 1996, in each country (1997 wave is the first in which the fifteen countries are included). In order to make comparisons available, European Union as a whole has been included as a new case of analysis in each period, taking its poverty line as the 50 % of the mean of total net household per capita income in EU.

If we observe poverty incidence between 1995 and 1999 (waves 3 to 7) in Figure 4, we can find that it increases in Finland, France and Sweden. In Denmark, poverty incidence increases, except in 1998, but the proportion of poor households has duplicate in this 5 years.

**Figure 4**  
*Poverty incidence in the EU and the European Countries.*

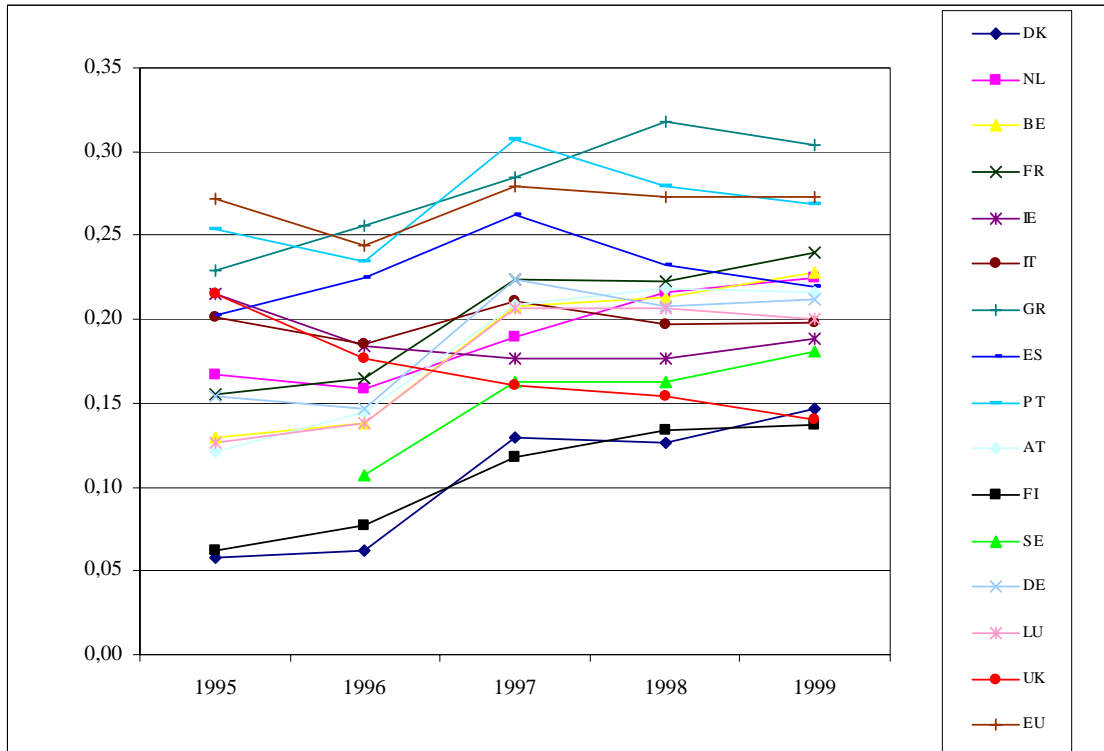

United Kingdom is the only country in EU where poverty incidence decreases, with respect to its own poverty line, fixed in 1996. In Greece, we find an increasing trend, diminished in 1998 and 1999. Nevertheless, Greece is the European Country with the biggest incidence of poverty, using the poverty line considered.

In Spain, there was an increasing trend up to 1997, when tendency changes, but in 1999 poverty incidence has become bigger than in 1995. Ireland has a stable level of poverty, whereas Finland, Denmark and Sweden show a remarkable increase in poverty incidence during this period.

#### 4.3. Poverty intensity trend comparison among European countries.

To summarize the information of the six poverty intensity indicators battery, we have computed, first, the cross-sectional synthetic indicators, whose weighting schemes are presented in Table 9.

**Table 9**

*Weighting scheme for the computation of the cross-sectional poverty indexes based on the first Principal Component.*

Poverty Index	Wave 3 1995	Wave 4 1996	Wave 5 1997	Wave 6 1998	Wave 7 1999
SEN	0.087026	0.087348	0.088534	0.085966	0.086695
THON	0.065490	0.065714	0.067734	0.065498	0.065614
FGT2	0.212179	0.211089	0.208157	0.208717	0.209290
FGT3	0.310278	0.310539	0.310965	0.322314	0.318722
EXPON	0.181338	0.181107	0.180194	0.177834	0.179134
CHACK075	0.143690	0.144204	0.144416	0.139671	0.140545

We have checked out that, as in the case of inequality indicators, we can assume that correlation matrices between poverty indicators are the same in each year considered (see Tables 10a and 10b).

**Table 10a**

*Box's M Test on equality of correlation matrices.*

Wave	Rank	Log of determinant
1995 correlation matrix	3	-31.645
1996 correlation matrix	3	-32.760
1997 correlation matrix	3	-32.096
1998 correlation matrix	3	-33.438
1999 correlation matrix	3	-33.577
Pooled correlation matrix	3	-32.354

**Table 10b**

*Results of M-Box Test.*

Box's M		26.868
F	Aprox.	1.019
	df1	24.000
	df2	15033.849
	Sig.	.436

Table 11 shows the weights to compute synthetic poverty indicators based on the Global First Principal Component and Common Space Analysis. The corresponding weighting schemes are almost identical, because the correlation matrices can be assumed to be equal in all periods considered.

**Table 11**

*Weighting scheme for the computation of the longitudinal poverty indexes based on the Global First Principal Component and the Common Space Analysis Technique.*

Poverty Index	Global Principal Component Indicator	Common Space Indicator
SEN	0,086227	0,086184
THON	0,065516	0,065470
FGT2	0,210949	0,210732
FGT3	0,315338	0,316124
EXPON	0,180098	0,179776
CHACK075	0,141872	0,141715

In order to analyse the equivalence of these synthetic indicators, Pearson and Spearman correlation coefficients have been computed to check that they are significantly linear related.. In Tables 12 and 13, these coefficients are shown. As it can be observed, they are unity, thus giving validity to the use of a synthetic indicator or another.

**Table 12**

*Pearson correlation coefficients between Global Principal Component indicator and Common Space Indicator. Poverty.*

		Global Principal Component Indicator	Common Space Indicator
Global Principal Component Indicator	Coefficient	1.000	1.000
	Significance		0.000
	N	79	79
Common Space Indicator	Coefficient	1.000	1.000
	Significance	0.000	
	N	79	79

**Table 13**

*Spearman correlation coefficients between Global Principal Component indicator and Common Space Indicator. Poverty.*

		Global Principal Component Indicator	Common Space Indicator
Global Principal Component Indicator	Coefficient	1.000	1.000
	Significance		0.000
	N	79	79
Common Space Indicator	Coefficient	1.000	1.000
	Significance	0.000	
	N	79	79

To prove that these synthetic indicators reflect well all the cross-sectional synthetic indicators, Pearson and Spearman correlation coefficients between them are given in Tables 14 and 15.

**Table 14**

*Pearson correlation coefficients between Global Principal Component indicator and Common Space Indicator and each year's Principal Component indicator. Poverty.*

		<b>Global Principal Component Indicator</b>	<b>Common Space Indicator</b>
<b>1995 Principal Component Indicator</b>	<b>Coefficient</b>	1.000	1.000
	<b>Significance</b>	0.000	0.000
	<b>N</b>	15	15
<b>1996 Principal Component Indicator</b>	<b>Coefficient</b>	0.999	1.000
	<b>Significance</b>	0.000	0.000
	<b>N</b>	16	16
<b>1997 Principal Component Indicator</b>	<b>Coefficient</b>	1.000	1.000
	<b>Significance</b>	0.000	0.000
	<b>N</b>	16	16
<b>1998 Principal Component Indicator</b>	<b>Coefficient</b>	0.999	0.999
	<b>Significance</b>	0.000	0.000
	<b>N</b>	16	16
<b>1999 Principal Component Indicator</b>	<b>Coefficient</b>	0.999	0.999
	<b>Significance</b>	0.000	0.000
	<b>N</b>	16	16

**Table 15**

*Spearman correlation coefficients between Global Principal Component indicator and Common Space Indicator and each year's Principal Component indicator. Poverty.*

		<b>Global Principal Component Indicator</b>	<b>Common Space Indicator</b>
<b>1995 Principal Component Indicator</b>	<b>Coefficient</b>	1.000	1.000
	<b>Significance</b>	0.000	0.000
	<b>N</b>	15	15
<b>1996 Principal Component Indicator</b>	<b>Coefficient</b>	1.000	1.000
	<b>Significance</b>	0.000	0.000
	<b>N</b>	16	16
<b>1997 Principal Component Indicator</b>	<b>Coefficient</b>	1.000	1.000
	<b>Significance</b>	0.000	0.000
	<b>N</b>	16	16
<b>1998 Principal Component Indicator</b>	<b>Coefficient</b>	1.000	1.000
	<b>Significance</b>	0.000	0.000
	<b>N</b>	16	16
<b>1999 Principal Component Indicator</b>	<b>Coefficient</b>	1.000	1.000
	<b>Significance</b>	0.000	0.000
	<b>N</b>	16	16

As the different correlation coefficients computed are very close to unity in all cases, we can conclude that results obtained with Common Space-Based synthetic indicator performs well as a longitudinal indicator of poverty intensity.

In Figure 5, we appreciate that Greece is the country in EU with a higher level in poverty intensity, followed by Portugal and Spain. Nevertheless, Italy, which in 1995 is at

the same level than Portugal and Greece, has always a decreasing trend, as UK. Although they have an increasing trend in poverty intensity, Denmark and Finland are the countries where poverty intensity has a lower but increasing effect.

**Figure 5**  
*Common Space Poverty Indicator values for each Country in the ECHP.*

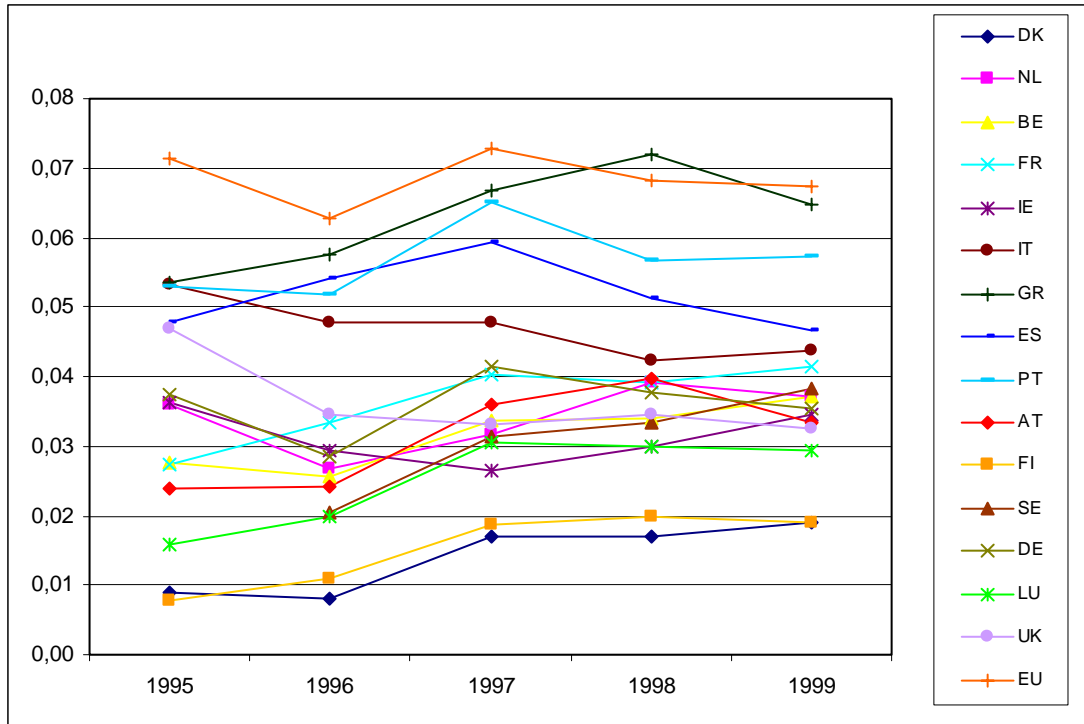

To analyse the different characteristics of EU countries, related to poverty intensity, a classification of cases has been accomplished. In Figure 6, we find three groups of countries:

- The first group is formed by Denmark and Finland, which present a lower level of poverty intensity.
- The second group is composed by France, The Netherlands, Germany, Belgium, Austria, Sweden, Ireland, United Kingdom and Luxembourg. These countries are located in the middle of poverty intensity figures, with an undefined behavior in poverty intensity trends.
- The third group comprises Spain, Portugal, Italy and Greece. These are the countries with a bigger intensity of poverty in the European Union.

**Figure 6**

*Dendrogram of the countries' common space based poverty index referred to waves 4, 5, 6 and 7. Centroid agglomeration method and squared euclidean distance have been used.*

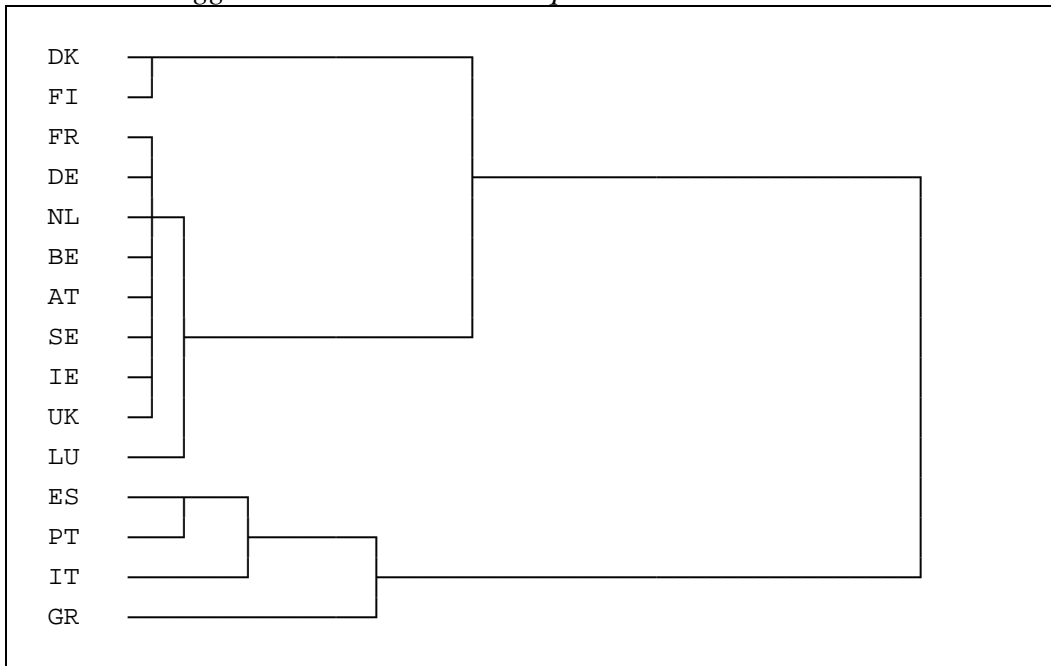

In Figure 7, the geographical situation of these three groups is represented.

**Figure 7**

*Geographical representation of the groups of countries derived from the classification.*

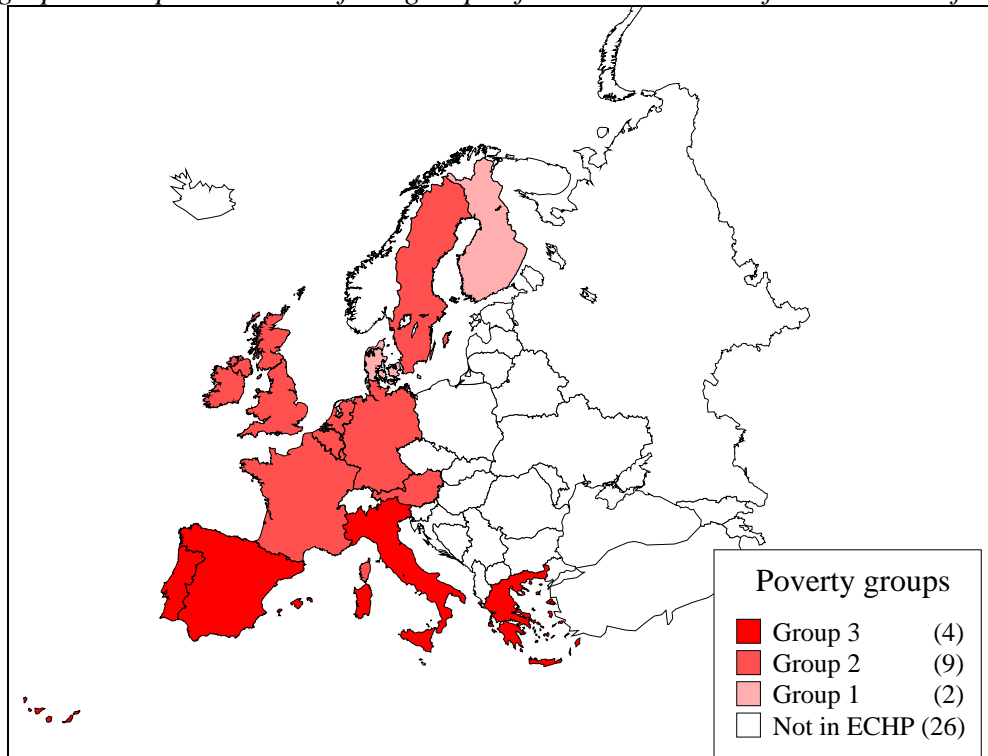

## 5. CONCLUSIONS

In this paper, we have proposed a methodology to construct a synthetic indicator, which comprises the information of a battery of poverty and inequality indicators verifying a set of good properties. The advantage of the exposed methodology is that we can evaluate inequality and poverty among countries, not only in the same period of time, but also in a longitudinal sense, with the same synthetic indicator. This approach allows us to overcome the problem which consists of the selection of a better inequality or poverty measure among the great number of proposed indicators. This methodology has proved to be useful to compare among cases, such as EU countries in this study. The unique drawback we find is the lack of economic interpretation of its results, because of its structure as a convex linear combination of simple indicators. Nevertheless, the possibility to compare cases taking into account information from a set of accepted indicators, without an explicit selection of one of them, overcomes this problem. Further research could be accomplished to explore the theoretical properties of the synthetic indicators proposed here, looking for economic implications of their results.

We have checked out that when correlation matrices, calculated over a set of variables measured on different groups or along time, can be assumed to be statistically identical, then Krzanowski's Common Space Analysis adaptation produces exactly the same results than Global First Principal Component-based synthetic indicator applied on the pooled correlation matrix. Furthermore, their respective coefficients have been proved to be close enough to each other.

Using household's total net income data provided by the ECHP, from 1994 to 2000 waves, we have computed all one-dimensional inequality indicators used to elaborate the synthetic inequality index proposed in the methodology. In this case, correlation matrices computed for the indicators in each wave have turned out to be identical, thus allowing us to construct the synthetic inequality indicator, whose weighting scheme is the same all over the period of time considered.

Attending to the empirical results, we have accomplished the classification of European countries in four groups according to their inequality degree, measured using the

synthetic indicator. The first group, and more equal, is composed by the Nordic Countries (Finland, Sweden and Denmark). The second group is composed by France, Germany, The Netherlands, Austria, Luxembourg and Italy. Belgium and United Kingdom, the third group, are countries in which inequality had a remarkable increase since 1996 to 1999 (waves 4 to 7). The last group (Spain, Portugal, Greece and Ireland) exhibits higher levels of inequality.

We have also analysed poverty among European countries. On the one hand, we have considered poverty incidence through the headcount ratio index. Nordic countries (Finland, Denmark and Sweden) present a lower incidence of poverty, which is related to their lower inequality levels. Nevertheless, their poverty incidence levels are increasing all over the period. Greece, Portugal and Spain present the higher poverty incidence levels along the period, while the rest of the countries remain in a middle class. Among this group, UK exhibits a remarkable behavior, because it is the only country in which the headcount ratio is always decreasing.

On the other hand, we have analysed poverty intensity taking the information from the battery of poverty intensity measures that have been selected. Results allow us to establish three groups: The first group (Denmark and Finland) present the lower levels of poverty intensity. In the opposite, Spain, Portugal, Italy and Greece form the group where poverty intensity is bigger in the EU.

To sum up, we can extract some general ideas about our empirical findings. First of all, general trends in inequality and poverty show a slight convergence of all countries in EU. Second, Nordic countries exhibit a moderate increasing of their measured levels, but keeping themselves on the lower band, while Southern countries (Portugal, Spain and Greece) remain at the upper band. The rest of the countries are in the middle, but they present different trend patterns.

## REFERENCES

- ACHDUT, L. (1996)** “Income inequality, income composition and macroeconomic trends: Israel, 1979-93”. *Economica*, 63, 250, S1-S27.
- ÁLVAREZ-GARCÍA, S.; PRIETO-RODRÍGUEZ, J.; SALAS, R. (2002)** “The Evolution of Income Inequality in the European Union”. *Papeles de Trabajo*, 10/02, Instituto de Estudios Fiscales, Serie Economía. Madrid.  
[[http://www.ief.es/Publicaciones/papelest/02/pt10\\_02.pdf](http://www.ief.es/Publicaciones/papelest/02/pt10_02.pdf)]
- ATKINSON, A.B. (1970)** “On the measurement of inequality”. *Journal of Economic Theory*, 2, pp. 244-263.
- ATKINSON, A.B. (1987)** “On the measurement of poverty”. *Econometrica*, 55(4), pp. 749-764.
- AYALA, L.; SASTRE, M. (2002)** “What determines Income Mobility differences across the European Union?”, *Working Papers of the Institute for Social and Economic Research*, paper 2002-27. Colchester: University of Essex.
- BISHOP, J.A.; FORMBY, J.P.; SAKANO, R. (1995)** “Lorenz and stochastic-dominance comparisons of European income distributions”. *Research on Economic Inequality*, 6, pp. 77-92.
- BISHOP, J.A.; FORMBY, J.P.; SMITH, W.J. (1991)** “Lorenz dominance and welfare: Changes in the U.S. distribution of income, 1967-1986”. *Review of Economics and Statistics*, 73, pp. 134-139.
- BOURGUIGNON, F. (1979)** “Decomposable income inequality measures”. *Econometrica*, 47, pp. 901-920.
- BUHMANN, B.; RAINWATER, L.; SCHMAUS, G.; SMEEDING, T.M. (1988)** “Equivalence Scales, Well-Being, Inequality and Poverty: Sensitivity estimates across ten countries using the Luxembourg Income Study (LIS) Database”. *Review of Income and Wealth*, 42, pp. 381-399.
- CASAS, J.M.; DOMÍNGUEZ, J.; NÚÑEZ, J.J. (2003)** “La pobreza en España: Estudio a partir de curvas I.I.D. y su sensibilidad frente a escalas de equivalencia”. In Casas, J.M. and Pulido, A. (Co-ords.) *Información Económica y Técnicas de Análisis en el Siglo XXI*. Ed. I.N.E., Madrid. Pages 161-173.

- COULTER, F.; COWELL, F.; JENKINS, S.P. (1992)** “Equivalence Scale relativities and the extent of Inequality and Poverty”, *Economic Journal*, 102, pp. 1067-1082.
- DAGUM, C. (1989)** “Poverty as perceived by the Leyden income evaluation project. A survey of Hagenaaers’ contribution on the perception of poverty”. *Economic Notes*, Vol. 1, pp. 101-111.
- DAGUM, C. (1990)** “Relationship between income inequality measures and social welfare functions”. *Journal of Econometrics*, 43, 1-2, pp. 91-102.
- DAVIES, J.B.; HOY, M. (1994)** “The normative significance of using third-degree stochastic dominance in comparing income distributions”. *Journal of Economic Theory*, 64(2), pp. 520-530.
- DAVIES, J.B.; HOY, M. (1995)** “Making inequality comparisons when Lorenz curves intersect”. *American Economic Review*, 85, 4, pp.980-986.
- DEL RÍO, C.; RUÍZ-CASTILLO, J. (2001)** “TIP’s for poverty análisis. The case of Spain, 1980-81 to 1990-91”. *Investigaciones Económicas*, XXV, 1, pp. 63-91.
- DUCLOS, J.-Y.; MERCADER-PRATS, M. (1999)** “Household needs and poverty: with application to Spain and the U.K.”. *Review of Income and Wealth*, 45(1), pp. 77-98.
- DOMÍNGUEZ, J. (2003)** *Análisis dinámico de la pobreza y la estructura de los hogares*. Tesis Doctoral. Universidad de Granada.
- DOMÍNGUEZ, J.; NÚÑEZ, J.J.; RIVERA, L.F. (2004)** “Evolución de la desigualdad y la pobreza en España, mediante indicadores sintéticos, a partir de la estructura de covarianza de indicadores simples. El caso de las Comunidades Autónomas de Galicia y Castilla-La Mancha (1997-2000)”. *VII Encuentro de Economía Aplicada*. Vigo, Spain. [Paper available at <http://www.revecap.com/viieea/autores/D/123.doc>]
- EUROSTAT (2003)** “ECHIP UDB Description of variables. Data Dictionary, Codebook and differences between Countries and Waves”. DOC. PAN 166 / 2003-12. Eurostat, Luxembourg.
- [<http://forum.europa.eu.int/irc/Download/k1eMAjJZmSGxH5NtD4GRcD2r6Rgc1SRI/scNqLj4I9If-YFXFO2jv/PAN166-200312.pdf>]
- FOSTER, J.E. (1984)** “On economic poverty: A survey of aggregated measures”. *Advances in Econometrics*, 3, pp. 212-251.
- FOSTER, J.E. (1985)** “Inequality Measurement”. In *Fair Allocation* (H.P. YOUNG, ed.), Proceedings of Symposia in Applied Mathematics, Vol. 33, Providence, American Mathematical Society, pp. 31-68.

- FOSTER, J.E.; SEN, A. (1997)** *On Economics Inequality. Expanded Edition: Annexe.* Clarendon Paperbacks. Oxford.
- FOSTER, J.E.; SHORROCKS, A.F. (1988a)** “Poverty orderings”. *Econometrica*, 56 (1), pp. 173-177.
- FOSTER, J.E.; SHORROCKS, A.F. (1988b)** “Poverty orderings and welfare dominance”. *Social Choice*, 5, pp. 179-198.
- FRICK, J.R.; GRABKA, M.M. (2003)** “Imputed rent and income inequality: A decomposition analysis for Great Britain, West Germany and the U.S.”. *Review of Income and Wealth*, 49, 4, pp. 513-537.
- GARCÍA, C.; NÚÑEZ, J.J.; RIVERA, L.F.; ZAMORA, A.I. (2002)** “Análisis comparativo de la desigualdad a partir de una batería de indicadores. El caso de las Comunidades Autónomas españolas en el período 1973-1991”. *Estudios de Economía Aplicada*, 20(I), pp. 137-154.
- HAGENAARS, A.J.M.; VAN PRAAG, B. (1985)** “A synthesis of poverty line definitions”. *Review of Income and Wealth*, 31, pp. 139-154.
- JENKINS, S.P. (1995)** “Accounting for inequality trends: Decomposition analyses for the UK, 1971-86”. *Economica*, 62, 245, pp. 29-63.
- JENKINS, S.P.; LAMBERT, P.J. (1997)** “Three I’s of poverty curves, with an analysis of UK poverty trends”. *Oxford Economic Papers*, 49, pp. 317-327.
- KENDALL, M.; STUART, A. (1977)** *The Advanced Theory of Statistics*. Vol. 1, 4<sup>a</sup> ed. C. Griffin. London.
- KERAMIDAS, E.M.; DEVLIN, S.S.; GNANADESIKAN, R. (1987)** “A graphical procedure for comparing the principal components of several covariance matrices”. *Communications in Statistics, B. Computation and Simulation*, 16, pp. 161-191.
- KRZANOWSKI, W.J. (1979)** “Between-groups comparison of principal components”. *Journal of the American Statistical Association*, 74, pp. 703-707. Correction note (1981), 76, pp. 1022.
- KRZANOWSKI, W.J. (1982)** “Between-groups comparison of principal components – some sampling results”. *Journal of Statistical Computation and Simulation*, 15, pp. 141-154.
- LADERCHI, C.R. (1997)** “Poverty and its many dimensions: The role of income as an indicator”. *Oxford Development Studies*, 25 (3), pp. 345-360.
- LAYTE, R.; MAÎTRE, B.; NOLAN, B; WHELAN, C.T. (2000)** “Persistent and Consistent Poverty in the 1994 and 1995 Waves of the European Community

Household Panel Study”. 26<sup>th</sup> General Conference of the International Association for Research in Income and Wealth. Cracow, 27<sup>th</sup> August to 2<sup>nd</sup> September 2000. Paper available at [www.econ.nyu/dept/iariw](http://www.econ.nyu/dept/iariw)

- LORENZ, M.O. (1905)** “Methods of measuring the concentration of wealth”. *Journal of the American Statistical Association*, 9, pp. 209-219.
- LOVELL, M.C. (1998)** “Inequality within and among nations”. *Journal of Income Distribution*, 8(1), pp. 5-44.
- MULIERE, P.; SCARSINI, M. (1989)** “A note on stochastic dominance and inequality measures”. *Journal of Economic Theory*, 49(2), pp. 314-323.
- NICOLETTI, C.; PERACCHI, F. (2002)** “A Cross-Country comparison of Survey Participation in the ECPH”, *Working Papers of the Institute for Social and Economic Research*, paper 2002-32. Colchester: University of Essex.
- NÚÑEZ, J.J. (2002)** “Mayoración de rentas, curvas de Lorenz y medidas de desigualdad económica”. Working Paper DTEE 02/07. Departamento de Estadística, Estructura Económica y O.E.I. Universidad de Alcalá.
- NYGARD, F.; SANDSTROM, A. (1981)** *Measuring income inequality*. Amqvist & Wiksell International. Stockholm.
- PENA, J.B.(dir.); CALLEALTA, F.J.; CASAS, J.M.; MEREDIZ, A.; NÚÑEZ, J.J. (1996)** *Distribución Personal de la Renta en España*. Ed. Pirámide. Madrid.
- RENCHER, A.C. (1995)** *Methods of multivariate analysis*. Wiley Series in Probability and Mathematical Statistics. Wiley Interscience. New York.
- RUÍZ-CASTILLO, J. (1987)** *La medición de la pobreza y la desigualdad en España 1980-81*. Banco de España. Estudios Económicos, 42, Madrid.
- SEN, A.K. (1973)** *On economic inequality*. Clarendon Press. Paperbacks. Oxford.
- SEN, A.K. (1976)** “Poverty: an ordinal approach to measurement”. *Econometrica*, 44(2), pp. 219-231.
- SHORROCKS, A. (1983)** “Ranking income distributions”. *Economica*, 50, pp. 3-18.
- SHORROCKS, A.; FOSTER, J.E. (1987)** “Transfer sensitive inequality measures”. *Review of Economic Studies*, 54, 3, pp. 485-497.
- THUROW (1969)** *Poverty and Discrimination*. The Brookings Institution. Washington D.C.